

Submittal

Job _____
 Location _____
 Submitted to _____
 Submittal Prepared by _____
 Approve Date _____
 Date _____

Fire Damper Series 75 Type A

UL Classified - 1½ Hour Rating, Static
 For use in installations rated less than 3 hours

Standard Profile (4¼") 22 Ga

Type A Damper
 Blades in air-stream

Available for vertical and horizontal installations

Standard fusible link - 165° F (optional 212° F)

Available in stainless steel

Vertical dampers are available in single-section sizes
 from 4" x 4" to 60" x 60"
 multi-section sizes to 120" x 120"

Horizontal dampers are available in single-section sizes
 from 4" x 4" to 40" x 60"
 multi-section sizes to 120" x 120"

Optional 22 Ga Sleeve available:
 8", 12", 17", 20", or 24" lengths (12" is standard)

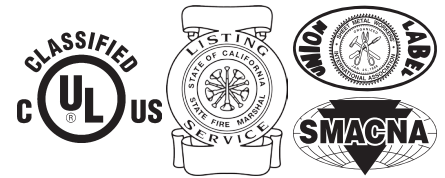
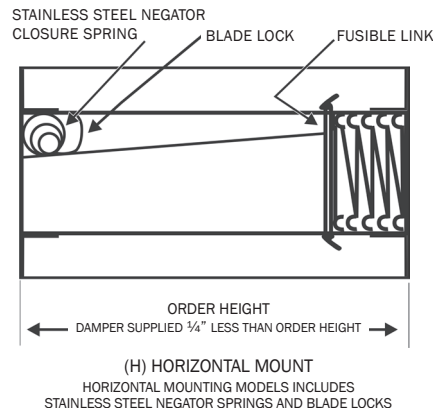
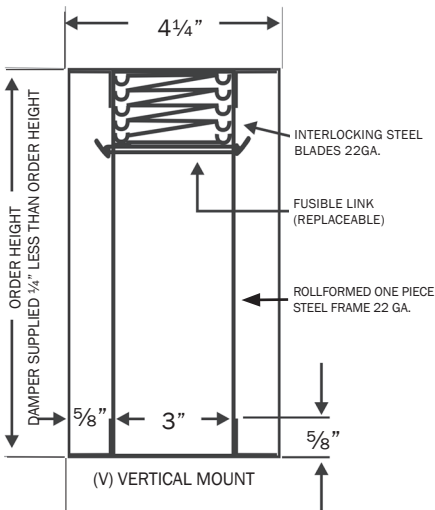
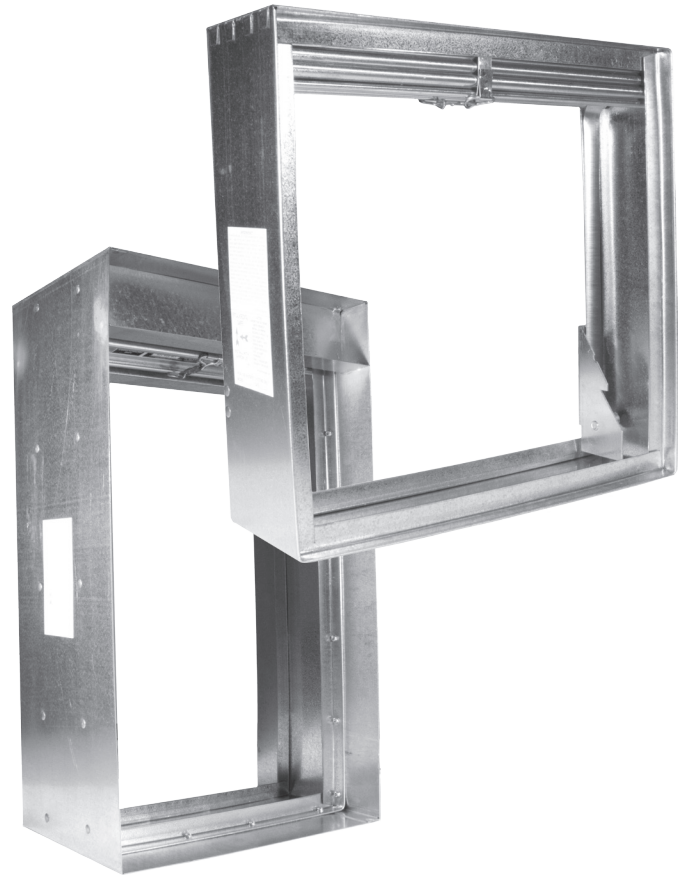

This product meets the requirements
 for fire dampers established by:

UL Standards 555
NFPA Standard 90A
ICC Building Codes

Qty.	Mount	Damper Size		Fusible Link Temp (165°F) std.	Factory Sleeve Length
	(V) vertical (H) horizontal	W	H		

Part Number Format

7 5 A H 0 2 4 0 1 8 G 2 2 1 2

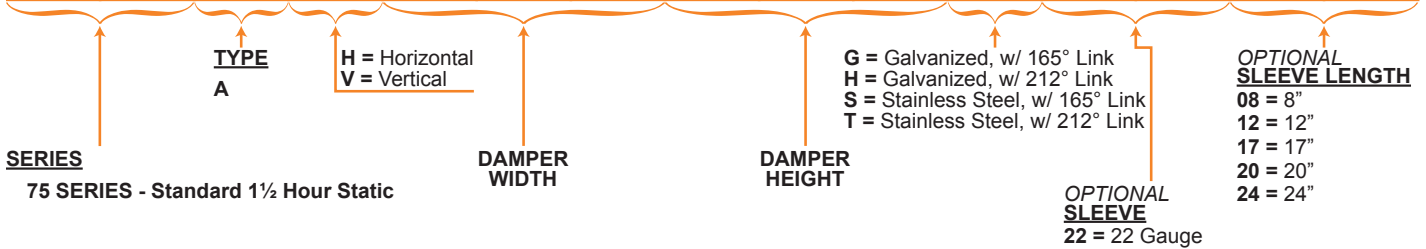

Submittal



AireTechnologies, Inc.
a DMI company

AireTechnologies, Inc.
1502 Industrial Drive
E. Monongahela, PA 15063

phone: 866.421.AIRE
fax 724.310.1262

www.airetechnologies.com